



**WIDEBAND CONTROLLERS**

**WB1 / WB2**

**QUICK START GUIDE**

## PRODUCT OVERVIEW

The Haltech Wideband Controller is a plug and play wideband solution for your Haltech system.

It allows users to accurately measure air/fuel ratios over a wide range, and deliver that information via CAN to a supported ECU of their choice.

This product increases functionality of all Haltech NEXUS, Elite and Platinum ECUs with its plug and play CAN compatibility. It is easily programmed and controlled through NSP, ESP or ECU Manager software.

There are two versions of WB1 and WB2 controllers, each version will control one of the following sensor types:

- BOSCH LSU 4.9
- NTK LZA08-H5



### What's in the box?

#### WB1 (Bosch/NTK) (HT-159976 or HT-159978)

- Single-Channel Wideband Controller
- 1200mm CAN Cable
- Bosch LSU4.9 OR NTK LZA08-H5 Sensor
- Oxygen Sensor Adaptor Harness
- 303SS Oxygen Sensor Bung
- DTM-4 Power Supply Cable
- Quick Start Guide



Haltech WB1 Kit Part Number: HT-159978

### What's in the box?

#### WB2 (Bosch/NTK) (HT-159986 or HT-159988)

- Dual-Channel Wideband Controller
- 1200mm CAN Cable
- (2) Bosch LSU4.9 OR (2) NTK LZA08-H5 Sensor
- (2) Oxygen Sensor Adaptor Harnesses
- 303SS Oxygen Sensor Bung
- DTM-4 Power Supply Cable
- Quick Start Guide



Haltech WB2 Kit Part Number: HT-159988

## WB MOUNTING

### Mounting

The Haltech Wideband Controller can be mounted to a flat surface in the engine bay using the two mounting holes provided in the enclosure.

The controller should be located as far as possible from any extreme sources of heat (exhaust, turbocharger, etc.)

Although the Haltech WB1 / WB2 Controllers are sealed units, it is good practice to mount them in an orientation that prevents water from collecting on the connector(s).

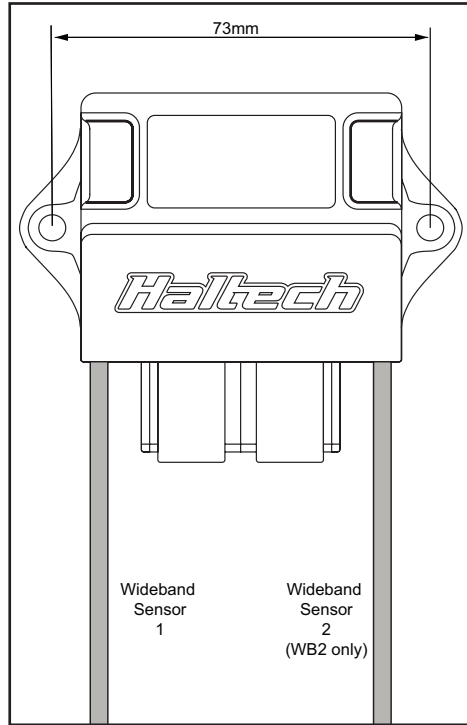

## WB WIRING / DAISY CHAIN SETUP

### Wiring

Connect the controller to the Haltech CAN Bus on your ECU by the integrated DTM-4 connector on your device.

Connect the NTK or Bosch LSU 4.9 Sensor(s) via the available pre-terminated cables from the controller.

Note: Haltech Wideband Controllers draw up to 4A per sensor during cold startup.

When running multiple controllers in a "daisy chain", they can require more power than the CAN Bus circuit delivers.

It is required to run a fused and switched 12V source (supplied by a relay) to power these controllers at Key On and Key Start positions.

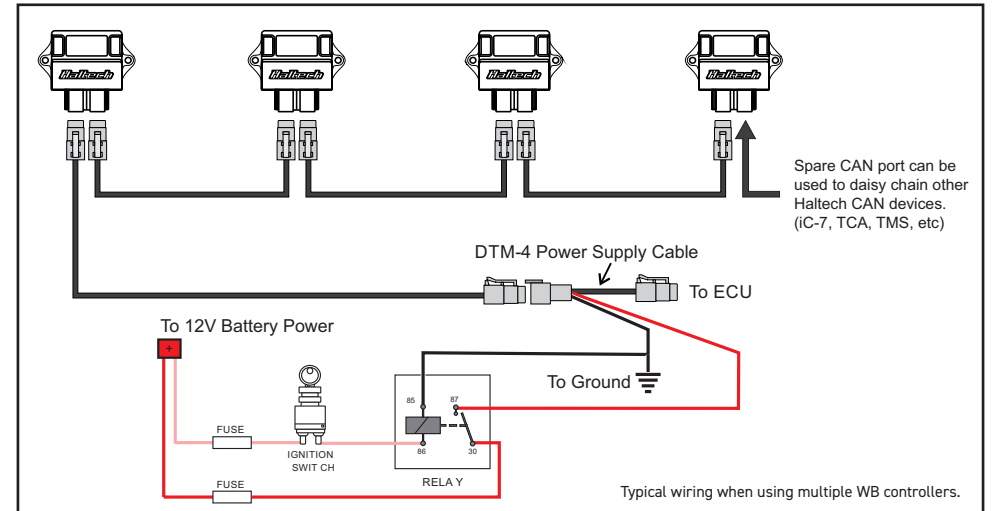

## DUAL CONNECTOR ECU WIRING

### Wiring for Elite Dual Connector ECUs

Connect the Haltech CAN Wideband Controller directly to a Haltech Elite Series ECU using the included DTM-4 Power supply cable and CAN cable DTM-4 to DTM-4 in series. Any CAN Port on the Haltech CAN Wideband Controller can be used.

Connect the DTM-4 Power supply cable RED wire to a fused and switched 12 Volt source that has power at

Key On and Key Start positions. For ease of installation this is available from the Elite ECU harness at Pin A26 (Red/Blue).

Connect the DTM-4 Power supply cable BLACK wire to a good ground source. For ease of installation this is available from the Elite ECU harness on Pin A10 (Black).

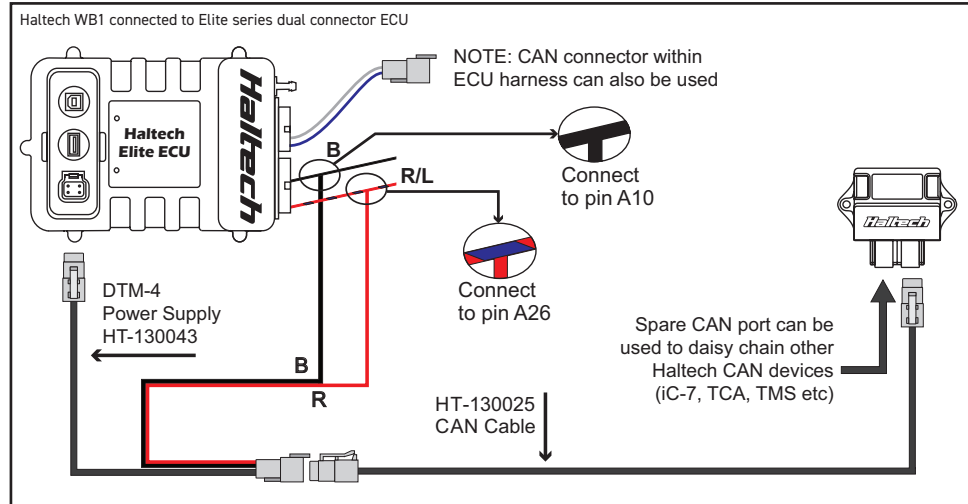

## SINGLE CONNECTOR ECU WIRING

### Wiring for Elite Single Connector ECUs

Connect the Haltech CAN Wideband Controller directly to a Haltech Elite Series single connector ECU using the CAN connector within the ECU harness, the included DTM-4 Power Supply Cable and CAN cable DTM-4 to DTM-4 as shown above.

Connect the DTM-4 Power supply cable RED wire to a fused and switched 12 Volt source that has power at

Key On and Key Start positions. For ease of installation this is available from the Elite ECU harness at Pin A26 (Red/Blue).

Connect the DTM-4 Power supply cable Black wire to a good ground source. For ease of installation this is available from the Elite ECU harness on Pin A10 (Black).

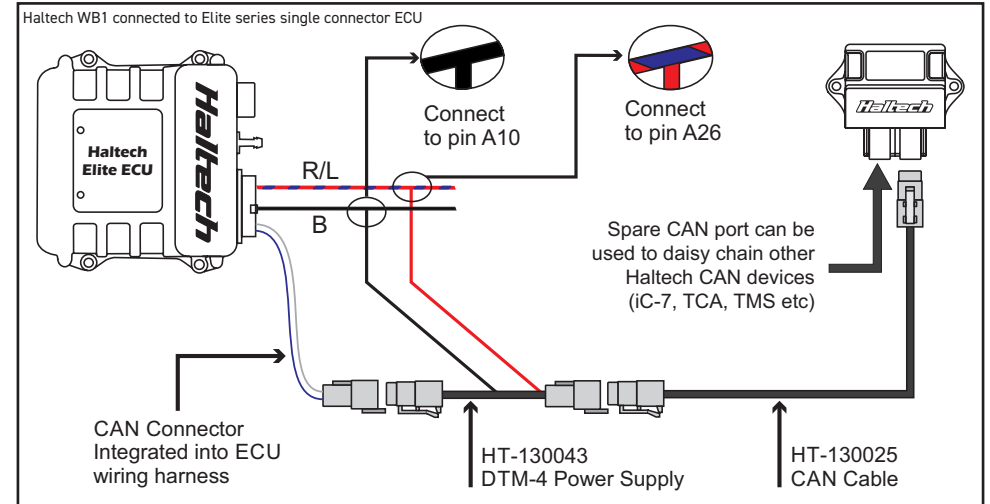

### Wiring for Elite Plug'n'Play Adapter Harness

Connect the Haltech CAN Wideband Controller to a Haltech Elite series ECU using the included DTM-4 Power supply cable and CAN cable DTM-4 to DTM-4 in series as shown below.

Connect the DTM-4 Power supply cable RED power wire to a fused and switched 12 Volt source that has power at Key On and Key Start positions. Connect the DTM-4 Power supply cable Black ground wire to a good ground source.

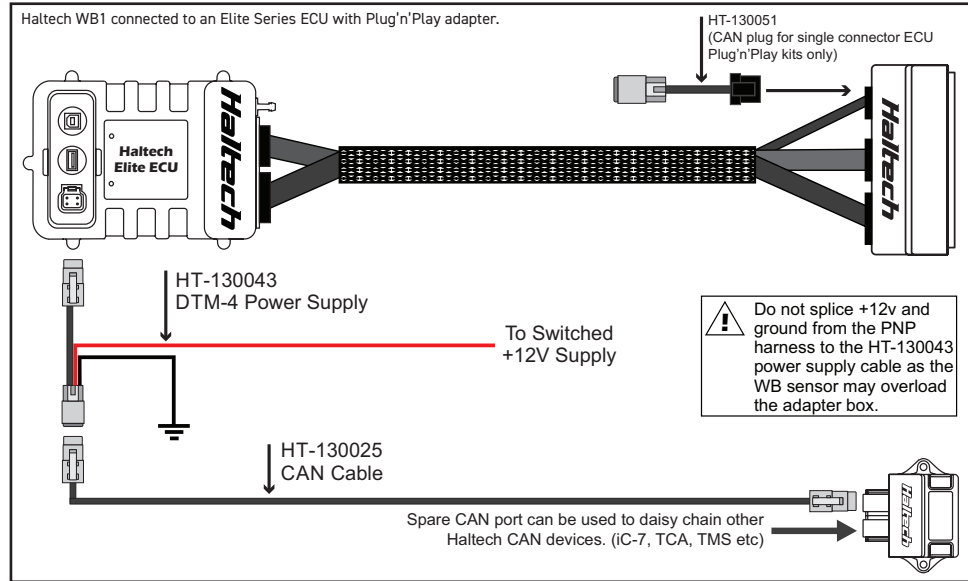

### Wiring for Platinum Pro Plug-in ECU

Connect the Haltech CAN Wideband Controller directly to a Haltech Platinum Series ECU using the included DTM-4 Power supply cable and CAN cable DTM-4 to DTM-4 in series with the DTM-4 to 8 pin Tyco CAN cable provided with the ECU as shown below.

Connect the DTM-4 Power supply cable RED power wire to a fused and switched 12 Volt source that has

power at Key On and Key Start positions. Connect the DTM-4 Power supply cable Black ground wire to a good ground source.

For ease of installation power and ground will be available from the vehicle harness please refer to your specific ECU's Quick start guide for reference and locations.

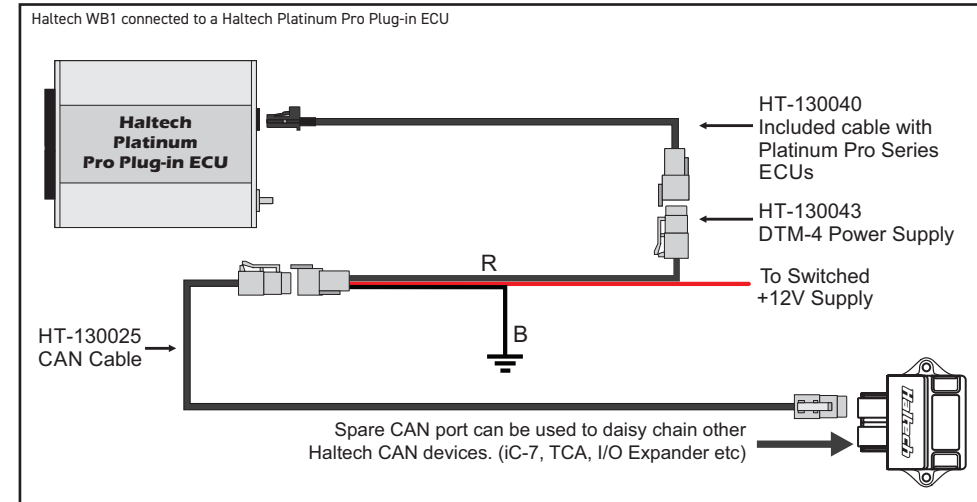

### Wiring for NEXUS R5 ECU

The NEXUS R5 has two on-board wideband controllers already, but we give you the option to add additional sensors. In order to use this feature, users will have to purchase single or dual WB controllers and wire them into the Haltech CAN BUS that the user has selected (CAN 1, 2 or 3).

Users will have to configure which WB controller they are using in the NSP software, including determining which CAN BUS they are using to transfer information to the VCU.

Basic harnesses can supply up to 8A of power draw for the CAN BUS wiring. It is recommended to use power harness, HT-130043 when connecting multiple devices where peak draw exceeds output of standard HCO.



The NEXUS R5 includes three separate CAN buses, users must select ONE HALTECH CAN network for unit to work correctly. Follow the chart below to identify which CAN networks are available for use.

Connector A:

Port 1 - CAN H (A23 White)  
CAN L (A24 Blue)

Connector B:

Port 3 - CAN H (B13 White)  
CAN L (B19 Blue)

Connector C:

Port 2 - CAN H (C21 White)  
CAN L (C22 Blue)

Haltech WB1 connected to NEXUS R5 VCU through CAN Network 2  
NOTE: CAN Network 1 or 3 may also be configured for this purpose.

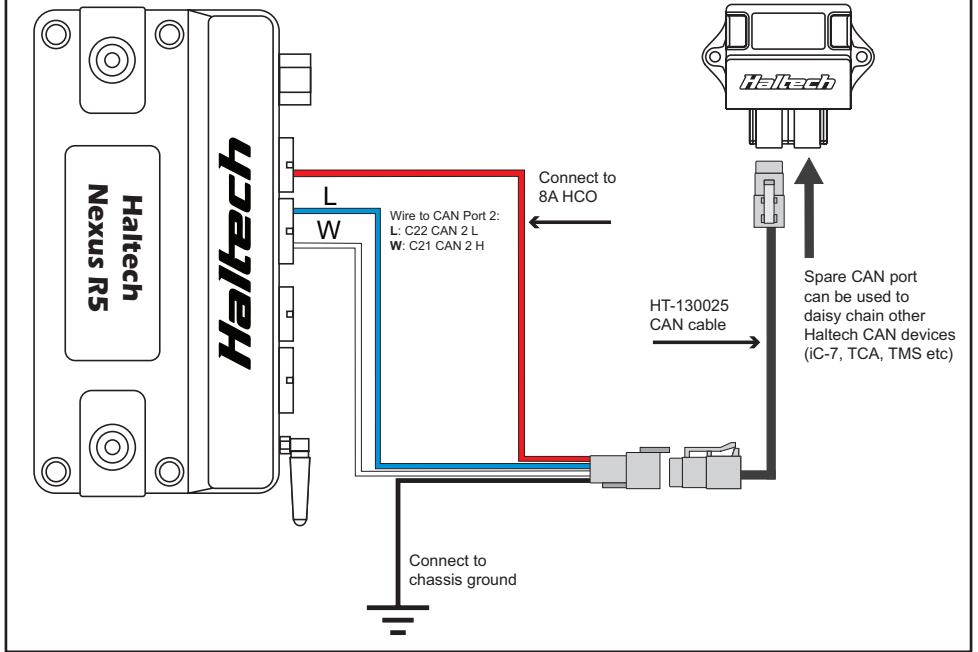

## Placement

The best location for the sensor is approximately 1 metre (3') from the closest exhaust valve (measured along the central axis of the exhaust pipe) or 1 metre (3') from the turbo outlet (for turbo charged vehicles).

## Mounting

The sensor requires the included 303SS bung to be welded into the vehicles exhaust system. Weld the bung into the chosen position and install the sensor.

It is recommended that the sensor be orientated in such a way that minimizes any condensation entering the sensor during warm up and operation.

## Wiring

Connect the wideband sensor to the pre-terminated 6 position connector on the Wideband Controller. Ensure all wiring is away from extreme heat sources and secured in place.

On a WB2 Controller the sensors are allocated as shown.

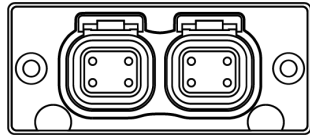

Wideband Sensor 1

Wideband Sensor 2

## Enabling Multiple Widebands

If two or more Haltech WB devices are connected to an ECU, each device must be allocated a unique device ID to function correctly. Haltech CAN wideband controllers are shipped from factory as device ID "A".

Up to 4 individual Haltech WB2 devices may be supported, depending on your ECU. Elite ECU's can update the device ID's through the Devices tab in ESP.

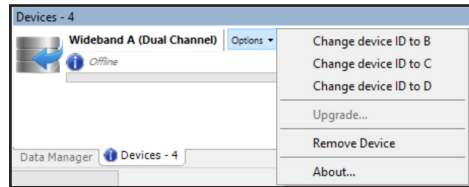

- Connect the Wideband to be updated and enable the device as previously noted.
- Select the "Options" tab and a menu will appear.
- Select "Change device ID to B".
- Connect the next device and repeat the process until each device is allocated a unique ID.

Once each device has a unique ID, the ECU must be reset. The sensors may now be enabled and allocated as wideband O2 sensor 1, 2, 3, 4 etc in the Functions tab.

NOTE: Devices which share the same ID will show an error if both devices are connected at the same time. One of the devices in error will need to be disconnected from the ECU before re-programming.

## NSP Software Setup

Now that your Haltech CAN Wideband Controller is installed, let's set it up in NSP software. With it powered and connected, your NEXUS will automatically recognize the new device.

To enable it, click on "Connections", select the drop down "CAN" and choose the "Haltech CAN System" prompt. Here we can enable our various CAN based devices.

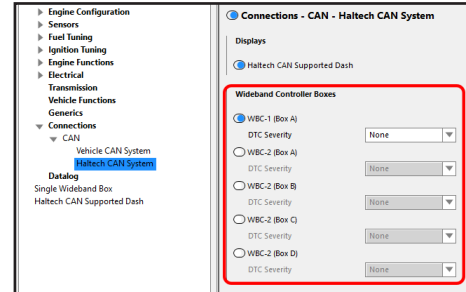

Once completed, reboot your NEXUS and select the new device menu item. Finish the setup by enabling your controller.

NOTE: To connect multiple WB2 devices, users will need to purchase pre-programmed units (Box B, C, & D) or speak with their dealer about reprogramming existing devices.

## Sensor Calibration (NTK sensor only)

To improve the accuracy of NTK sensors and to better compensate for variations in individual sensors due to manufacturing tolerances and or age and wear, a free air calibration must be done prior to using a new sensor or when changing to a different (spare) one.

To perform this properly, the NTK sensor must be outside the exhaust system so it can read free air.

When ready, begin the calibration process by clicking on the Calibrate button found in the wiring page under Wideband O2. The calibration process may take 1-2 minutes as it requires time for the sensor to heat up from cold. The sensor value will display as "Calibrating" during this time, then show "Free Air" if the calibration was successful.

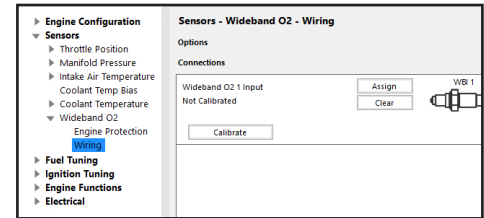

NOTE: The NTK sensor free air calibration requires the minimum software / firmware versions:

- NSP software 1.34 (feature not available in ESP or ECU Manager)
- Nexus VCU firmware 1.22 or Elite ECU firmware 3.08
- Haltech WB1 or WB2 controller firmware 3.10

## PRODUCT SPECIFICATIONS

WB1	
Size	86mm x 77mm x 28mm / 3.39" x 3.03" x 1.10"
Sensor Compatibility**	Bosch LSU 4.9 or NTK LZA08-H5
Supply Voltage	6.5V to 16V DC, Short circuit,reverse polarity protection
Supply Current	650mA Typical / 4A Peak
Maximum Temperature	85C (185F)
Communications	CAN (Haltech) with baud rate of 1Mbit/sec
Configuration	Haltech NSP Software, ESP Software, or ECU Manager
CAN Connection	2 x DTM-4 Connectors / 1 x DTM04-6P Connection

WB2	
Size	86mm x 77mm x 28mm / 3.39" x 3.03" x 1.10"
Sensor Compatibility**	Bosch LSU 4.9 or NTK LZA08-H5
Supply Voltage	6.5V to 16V DC, Short circuit,reverse polarity protection
Supply Current	1.3A Typical / 8A Peak
Maximum Temperature	85C (185F)
Communications	CAN (Haltech) with baud rate of 1Mbit/sec
Configuration	Haltech NSP Software, ESP Software or ECU Manager
CAN Connection	2 x DTM-4 Connectors / 2 x DTM04-6P Connection

\*\* Sensors are compatible with specific WB1/WB2 Controllers. ie. NTK WB1 only compatible with NTK sensor.



## WARRANTY CERTIFICATE

*At Haltech we make every effort to design and manufacture fault-free products that perform up to or above the market expectations. All our products are covered by a Limited 12 Month Warranty.*

### Haltech Limited Warranty

Unless specified otherwise, Haltech warrants its products to be free from defects in material or workmanship for a period of 12 months from the date of purchase.

If the Haltech product is found to be defective as mentioned above, it will be replaced or repaired if returned prepaid along with proof of purchase. Proof of purchase in the form of a copy of the original purchase invoice, receipt or bill of sale which indicates that the product is within the warranty period, must be presented to obtain warranty service.

Replacement or repair of a defective product shall constitute the sole liability of Haltech. To the extent permitted by law, the foregoing is exclusive and in lieu of all other warranties or representations, either expressed or implied, including any implied warranty of merchantability or fitness. In no event shall Haltech, be liable for special or consequential damages.

### Product Returns

Please include a copy of the original purchase invoice, receipt or bill of sale along with the unused, undamaged product and its original packaging. Any product returned with missing accessory items or packaging will incur extra charges to return the item to a re-saleable condition.

All product returns must be sent via a freight method with adequate tracking, insurance and proof of delivery services. Haltech will not be held responsible for product returns lost during transit.

### Returns of Products Supplied in Sealed Packaging

The sale of any sensor or accessory supplied in sealed packaging is strictly non-refundable if the sealed packaging has been opened or tampered with. This will be clearly noted on the product packaging. If you do not accept these terms please return the sensor in its original unopened packaging within 30 days for a full refund.

A sensor or accessory product may be returned after 30 days of purchase (with its sealed packaging in tact) for credit only (no refunds given) and will be subject to a 10% restocking fee.

### Installation of Haltech Products

No responsibility whatsoever is accepted by Haltech for the fitment of Haltech Products. The onus is clearly on the installer to ensure that both their knowledge and the parts selected are correct for that particular application. Any damage to parts or consequential damage or costs resulting from the incorrect installation of Haltech products are totally the responsibility of the installer.

Always disconnect the battery when doing electrical work on your vehicle. Avoid sparks, open flames or use of electrical devices near flammable substances. Do not run the engine with a battery charger connected as this could damage the ECU and other electrical equipment.

Do not overcharge the battery or reverse the polarity of the battery or any charging unit. Disconnect the Haltech ECU from the electrical system whenever doing any welding on the vehicle by unplugging the wiring harness connector from the ECU.

After completing the ECU installation, make sure there is no wiring left un-insulated. Uninsulated wiring can cause sparks, short circuits and in some cases fire. Before attempting to run the engine ensure there are no leaks in the fuel system. All fuel system components and wiring should be mounted away from heat sources, shielded if necessary and well ventilated. Always ensure that you follow workshop safety procedures. If you're working underneath a jacked-up car, always use safety stands!

### Haltech Off-Road Usage Policy

In many states it is unlawful to tamper with your vehicle's emissions equipment. Haltech products are designed and sold for sanctioned off-road/competition non-emissions controlled vehicles only and may never be used on a public road or highway.

Using Haltech products for street/road use on public roads or highways is prohibited by law unless a specific regulatory exemption exists (more information can be found on the SEMA Action Network website [www.semanet.com/emissions](http://www.semanet.com/emissions) for state by state details in the USA).

It is the responsibility of the installer and/or user of this product to ensure compliance with all applicable local and federal laws and regulations. Please check with your local vehicle authority before purchasing, using or installing any Haltech product.





### **Haltech Australia**

17 Durian Place,  
Wetherill Park NSW 2164  
Australia  
Phone: +61 2 9729 0999  
Email: [aus@haltech.com](mailto:aus@haltech.com)

### **Haltech New Zealand**

9/B Weza Lane, Kumeu NZ 0810  
Phone: 09 887 0616  
Email: [nz@haltech.com](mailto:nz@haltech.com)

### **Haltech USA East**

750 Miles Point Way,  
Lexington, KY USA 40510  
Phone: (888) 298 8116  
Email: [usa@haltech.com](mailto:usa@haltech.com)

### **Haltech USA West**

Race Winning Brands,  
10800 Valley View Street,  
Cypress, CA 90630  
Phone: (888) 298 8116  
Email: [usa@haltech.com](mailto:usa@haltech.com)

### **Haltech UK**

Unit 1, Miras Business Estate,  
Keys Park Road, Hednesford,  
WS12 2FS  
Phone: +44 121 285 6650  
Email: [uk@haltech.com](mailto:uk@haltech.com)

### **Haltech Europe**

Ottogasse 2A,  
2333 Leopoldsdorf, Austria  
Phone: +43 720 883968  
Email: [europe@haltech.com](mailto:europe@haltech.com)



[facebook.com/HaltechEngineManagement](https://facebook.com/HaltechEngineManagement)



[youtube.com/haltechecu](https://youtube.com/haltechecu)



[instagram.com/haltechecu](https://instagram.com/haltechecu)