

# Bosch 68mm Electronic Throttle Body - includes plug and pins

Used to electronically control the throttle and provide throttle position to the ECU. This device is used together with an Accelerator Pedal Position (APP) sensor and an ECU that supports Drive By Wire throttle control.

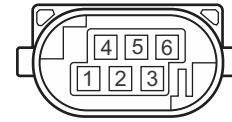
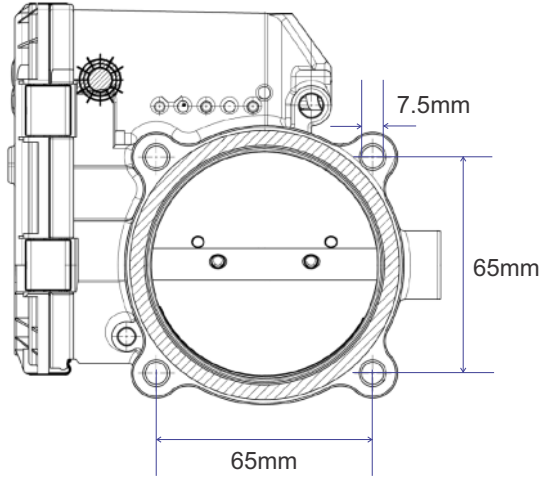

Looking into connector on electronic throttle body

## Pinout and Wiring Information

Pin	Function	ECU connection
1	Motor -	DBW Motor Output or HBO
2	Signal Ground	Signal Ground
3	+5V in	+5V
4	Motor +	DBW Motor Output or HBO
5	TPS 2	Analogue Voltage Input
6	TPS 1	Analogue Voltage Input

Please take care when wiring this electronic throttle body as incorrect wiring will damage it. Refer to your ECU's wiring diagram for specific wiring information.

## Haltech ECU Calibration Information

- 1.) After wiring the electronic throttle body and pedal assembly, connect the ECU to the tuning software (NSP) and go to the calibration section under Drive By Wire.
- 2.) To calibrate the pedal, click on the calibrate button with the pedal not depressed. Then click calibrate again with the pedal fully depressed.
- 3.) To calibrate the throttle, click on the calibrate button for the throttle to initiate the automatic calibration procedure.

HT-011801



Revision #1

### Need more help?



AUS: +61 2 9729 0999  
Europe: +43 720 883 968

USA: (888) 298 8116  
UK: +44 121 285 6650

NZ: +64 988 706 16



[www.haltech.com/support](http://www.haltech.com/support)



[support@haltech.com](mailto:support@haltech.com)

This device is strictly non-refundable if this packaging has been opened or tampered with. This device has been individually electronically tested before packaging and is sold "as is" and without any further warranty. If you do not accept these terms please return this device in its original unopened packaging for a full refund.



(inc plug & pins)

Bosch 68mm Electronic  
Throttle Body

HT-011801



Haltech Off-Road Usage Policy

In many states it is unlawful to tamper with your vehicle's emissions equipment.

Haltech products are designed and sold for sanctioned off-road/competition, non-registered or Haltech products are designed and sold for sanctioned off-road/competition, non-registered or using Haltech products for street/road use on public roads or highways is prohibited by law unless a specific regulatory exemption exists (more information can be found on the EMA Action Network website [www.semason.com/emissions](http://www.semason.com/emissions) for state details in the USA).

It is the responsibility of the installer and/or user of this product to ensure compliance with all applicable local and federal laws and regulations. Please check with your local vehicle authority before purchasing, using or installing any Haltech product.

**Installation of Haltech Products**

No responsibility whatsoever is accepted by Haltech for the fitment of Haltech Products. The user is clearly on the installer to ensure that both their knowledge and the parts selected are correct for that particular application. Any damage to parts or consequential damage or costs resulting from the incorrect installation of Haltech products are totally the responsibility of the installer.

Unless specified otherwise, Haltech warrants its products to be free from defects in material or workmanship for a period of 12 months from the date of purchase. Proof of purchase in the form of a copy of the original purchase invoice, receipt or bill of sale which indicates that the product is within the warranty period, must be presented to obtain warranty service. If the Haltech product is found to be defective as mentioned above, it will be replaced or repaired if returned prepaid along with proof of purchase. This shall constitute the sole liability of Haltech. To the extent permitted by law, the foregoing is exclusive and in lieu of all other warranties or representations, either expressed or implied, including any implied warranty of merchantability or fitness. In no event shall Haltech, be liable for special or consequential damages.

**Product Returns**

Please include a copy of the original purchase invoice, receipt or bill of sale along with the unused, undamaged product and its original packaging. Any product returned with missing accessory items or packaging will incur extra charges to return the item to a re-salable condition. All product returns must be sent via a freight method with adequate tracking, insurance and proof of delivery services. Haltech will not be held responsible for product returns lost during transit. The sale of any sensor or accessory that is supplied in sealed packaging is strictly non-refundable if the sealed packaging has been opened or tampered with. This will be clearly noted on the product packaging. If you do not accept these terms please return the sensor in its original unopened packaging within 30 days for a full refund.

**Returning a sensor or accessory product within 30 days of purchase:** Product may be returned for credit or full refund. (Any sealed packaging must not have been opened or tampered with)

**Returning a sensor or accessory product after 30 days of purchase:** Product may be returned for credit only (no refunds given) and is subject to a 10% Restocking fee. (Any sealed packaging must not have been opened or tampered with)

Version 6.0