

# PROFLOW

## INSTALLATION MANUAL

### TYPICAL FORD WIRING DIAGRAM

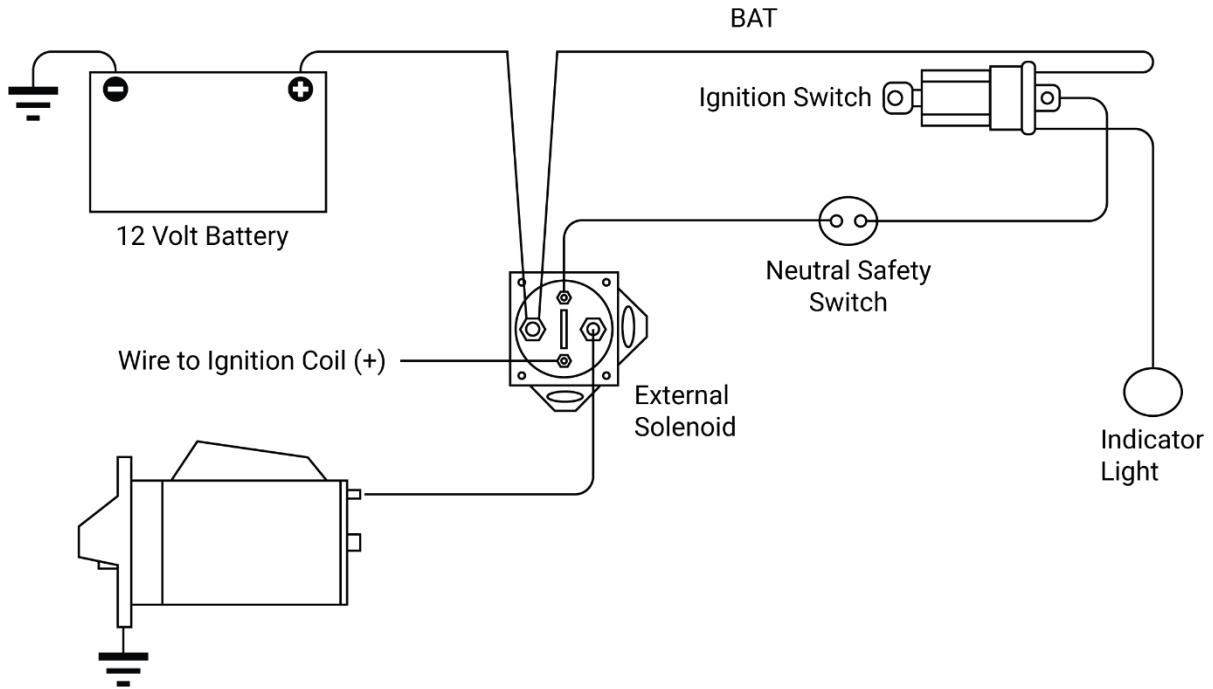

### CONVERTING CLAPPER STARTER TO PROFLOW GEAR REDUCTION STARTER

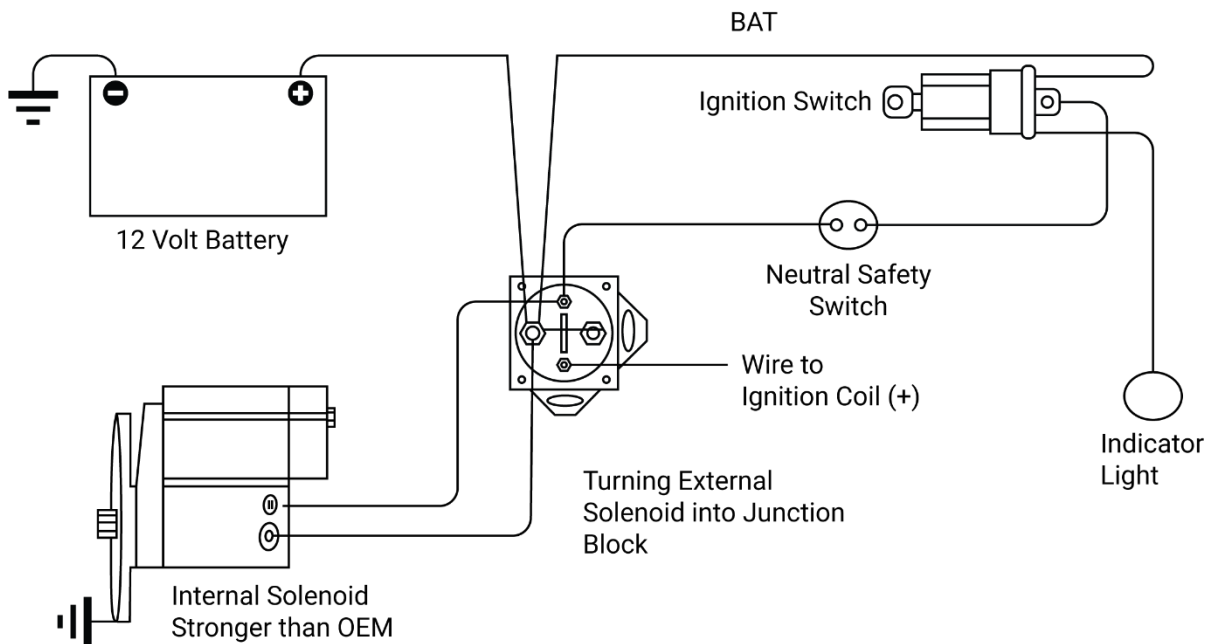

**Note: Ford solenoid can be removed and unit can be wired direct eliminating it as a junction block.**