



INSTALLATION MANUAL

Universal Hot Rod Windscreen Wiper Set

PFEHRW-400

Included Items	QTY
PFEHRW-400 Universal Hot Rod Windscreen Wiper Set	1

WARNING: PLEASE READ ALL INSTRUCTIONS BEFORE PROCEEDING. PROFLOW WILL NOT BE RESPONSIBLE FOR ANY DAMAGE AS A RESULT OF THE INCORRECT INSTALLATION OF THIS PRODUCT. IT IS RECOMMENDED THAT A QUALIFIED AUTOMOTIVE TECHNICIAN PERFORMS THIS INSTALLATION.

TYPICAL INSTALLATION

1. Determine a suitable area to mount the wiper motor and wiper shafts. Wiper motors are generally mounted under the dash or behind the firewall of a vehicle. All three components must line up with each other. Bending of aluminium tubing may be required, but only to a small degree to avoid binding of coil drive cable. Take into consideration the sweep rotation and park position of the wiper arms and clearance issues before all holes are drilled.
2. To mount wiper motor, drill 4 – 5/32" holes (figure 1).

NOTE: Metal plate bolted to the back of the wiper motor may be used as a template when mounting.

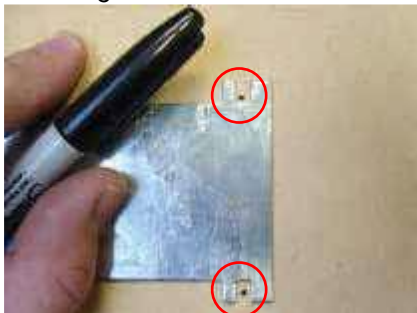

Figure 1

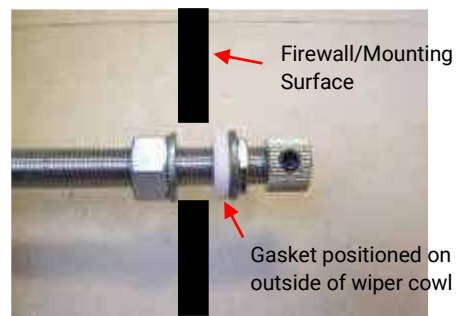

Figure 2

3. To mount the wiper shafts, drill a 3/8" hole for each location. Use masking tape to avoid scratching paint. Be sure the holes drilled into the wiper cowl are at a 90° angle to the windshield. Remove splined end with allen wrench and remove nut, washer and gasket. Insert wiper shaft into the hole and tighten nut, washer and gasket. Adjust to correct mounting depth. Shafts may also need to be shortened. Gasket must be on outside to avoid damage to paint and to seal from the elements of nature (figure 2).
4. If wiper shafts need to be shortened, disassemble units by unscrewing nuts. Remove the gear shaft. Mark the gear shaft and threaded housing to correct length. Remember gear shaft will be longer than threaded housing. There needs to be an

extra 3/8" of shaft past the end of the threaded housing. Cut both pieces separately, deburr and reassemble (figure 3).



Figure 3

5. Measure the distance between the two wiper shafts. Cut aluminium tube to correct distance. Do the same with the space between the wiper motor and closest wiper shaft (figure 4). Once aluminium is cut and installed, all pieces should fit together as shown in figure 5.

NOTE: Be sure the tubes do not touch the wiper shaft gear when installing.

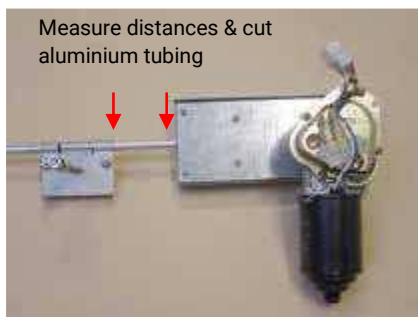

Figure 4



Figure 5

6. Feed the coil drive cable through the aluminium tubes and wiper shafts (figure 6). Make sure the wiper shafts spin when coil is fed through gear. The remaining coil can be cut once installation is finalised.

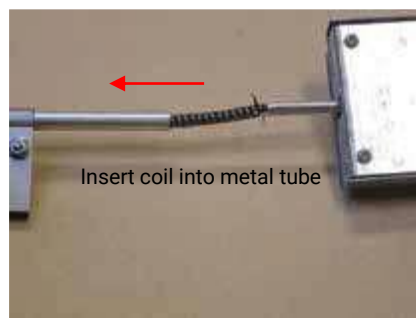

Figure 6

7. Plug in provided wire and run from wiper motor to dash. Determine the location for wiper switch. Drill a 1/2" hole clear of any wires or other equipment in dash. Follow provided wiring diagram.
8. Test, make adjustments, and apply grease to all moving parts.

WIRING DIAGRAM

Connect plug on motor to plug on wiring harness and connect wires from harness as shown below.

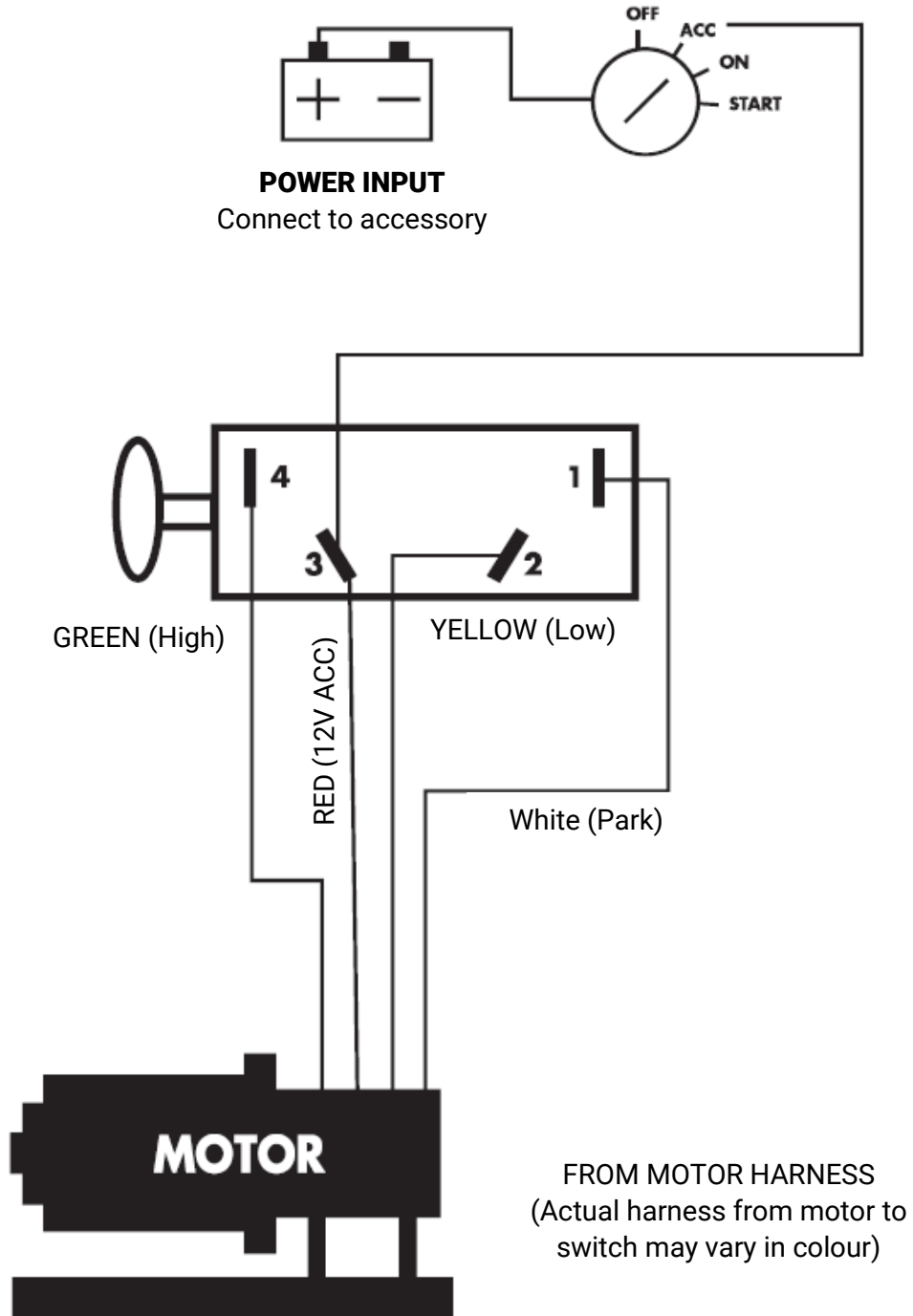

FIGURE 1

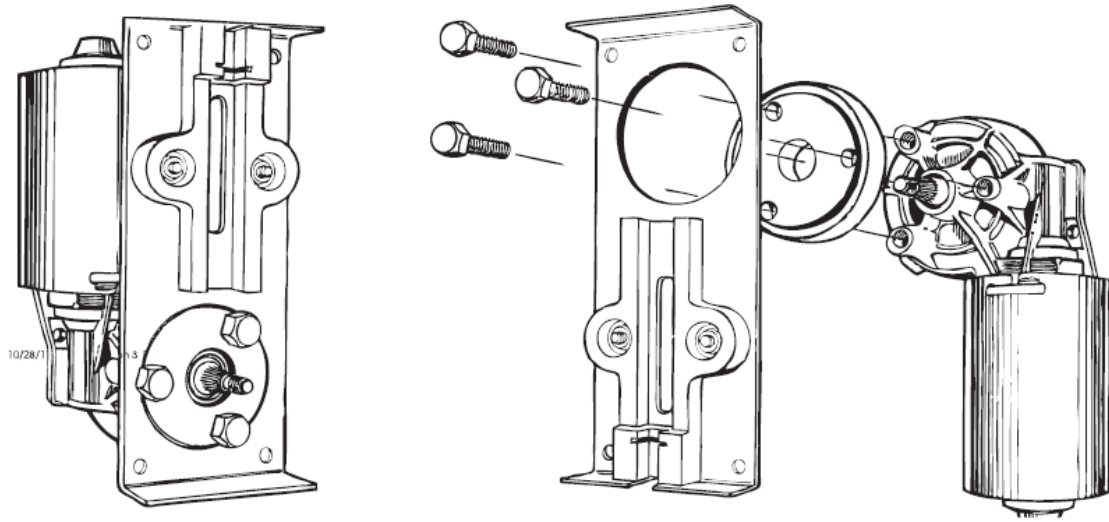

FIGURE 2

Motor must be in park position before setting sweep.

For the wipers to park at the end of the stroke, the link must be straight in line with slider on wiper cable. Also you must place the drive wheel with the sweep hole you select, straight in line with the drive cable and link.

The cover must be re-installed on the gear housing before each test.

INCORRECT

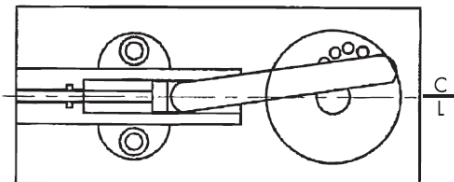

INCORRECT

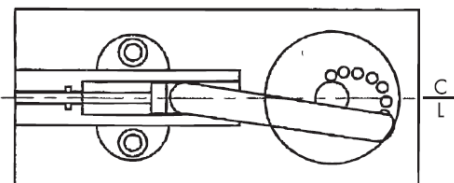

CORRECT

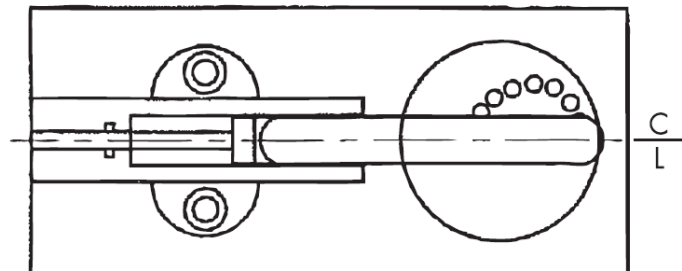

FIGURE 3

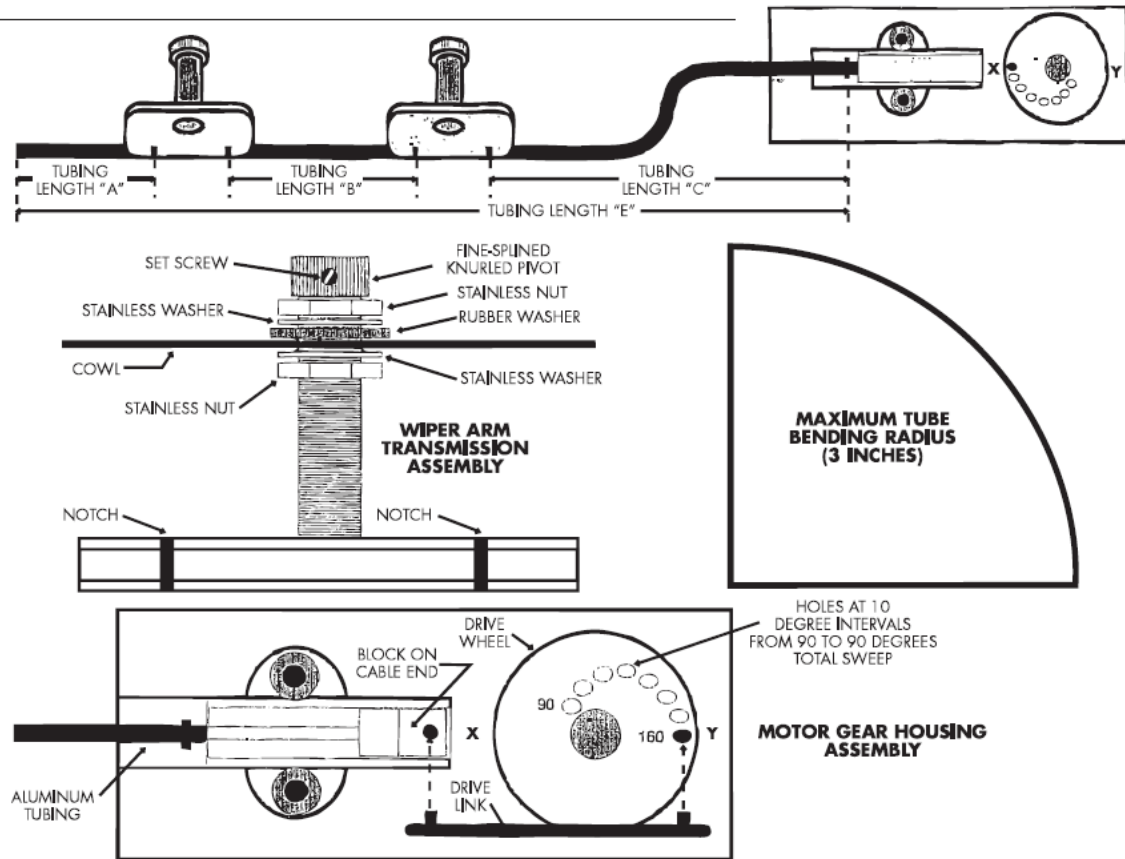
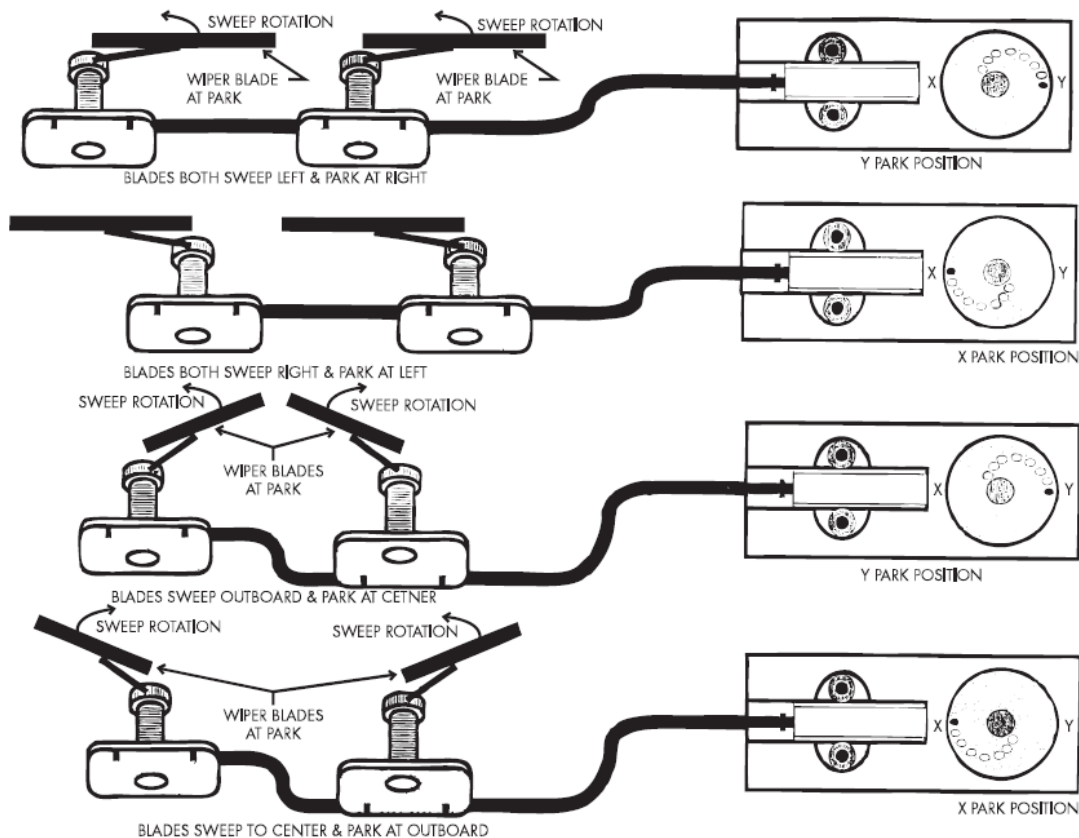
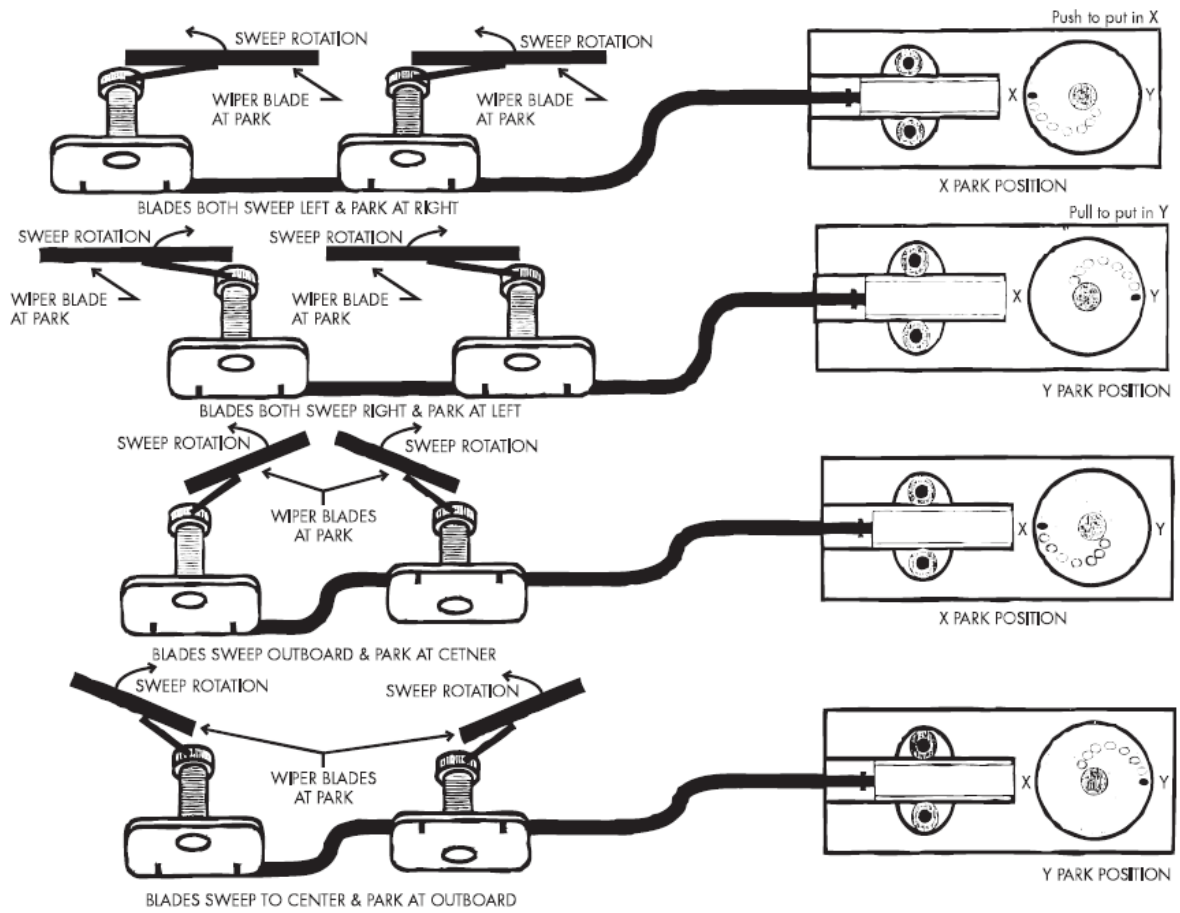

FIGURE 4



PROFLOW LIMITED WARRANTY

FIGURE 5



FAQ

Why are the metal tubes so long?

This is a universal kit. The tubes must be cut to correct length depending on vehicle and mounting points of wiper shafts. The two tubes separate the wiper motor from the wiper shaft, separate the two wipers shafts and provide a place to feed the coil drive cable through.

What is the distance between wiper shafts?

Distance varies depending on vehicle application. First choose correct length wiper arms (not included). Using wiper arms, you can determine what area they will cover on your windshield. Try different pivot points until a satisfactory location is found for mounting the wiper shafts.

How do I mount the wiper motor?

Mount the wiper motor on firewall or other location below windshield. Use the reinforcing bracket attached to the back of the wiper motor as a template to mark holes. Mark mounting location and use 1/8" drill bit to make holes. Make sure when mounting the wiper motor, that the metal tubes will be in a straight line to the wiper shafts. Coil drive cable will bind up if all components do not line up.

Where do I get wiper arms to fit this kit?

Since this is a universal kit, the length of wiper arm will vary depending on the size of your windshield. A good place to start is using the original wipers for your vehicle if they are available. If not try your local auto parts store and do not forget to bring the wiper shaft. This kit is similar to many wiper systems from English automobiles in the 50's and 60's. Note the model and year of the vehicle in which your wiper arms originated. It will make purchasing wipers blades much easier in the future.