



INSTALLATION MANUAL

Holden V8 VN Cylinder Heads – EFI

PFEAHH20063-EFI / PFEAHH20063-EFI-BARE

Included Items	QTY
PFEAHH20063 Aluminium Cylinder Head Pair	1

WARNING: PLEASE READ ALL INSTRUCTIONS BEFORE PROCEEDING. PROFLOW WILL NOT BE RESPONSIBLE FOR ANY DAMAGE AS A RESULT OF THE INCORRECT INSTALLATION OF THIS PRODUCT. IT IS RECOMMENDED THAT A QUALIFIED AUTOMOTIVE TECHNICIAN PERFORMS THIS INSTALLATION.

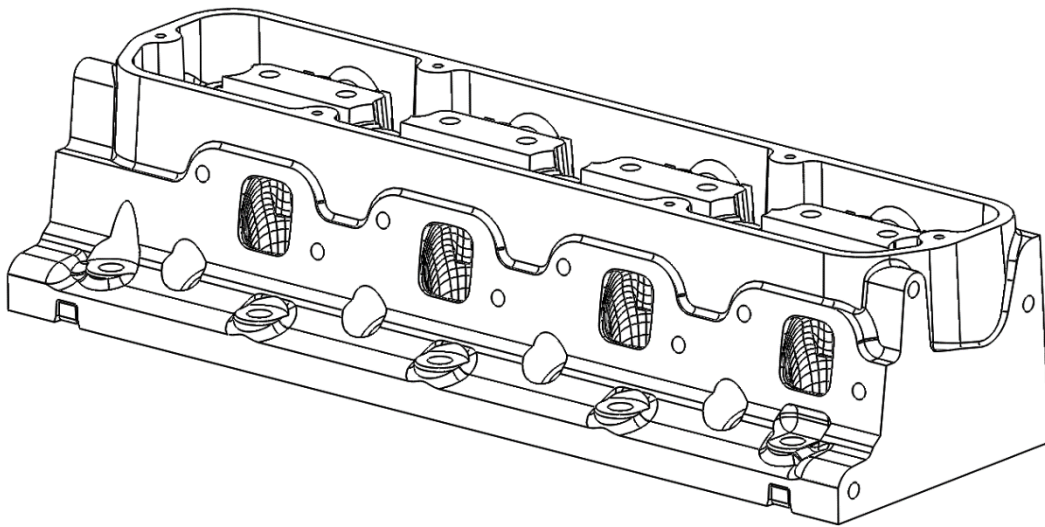

These cylinder heads are designed to suit either EFI or carburetted Holden Commodore VN 5.0L applications. This cylinder head is perfect for street performance use, daily drivers or even when high-end performance is required. It operates best in the ranges of 1500 to 6500 RPM and can either be purchased in a bare or assembled variation.

Before Installation

If you purchased bare cylinder heads, you will require extra components such as valves, valve springs, spring seats, retainer locks and seals. These components are highly recommended to be installed by a professional cylinder head assembler. When selecting valve springs, check with the camshaft manufacturer for recommended valve springs to achieve the correct spring pressures & valve lift.

High quality head studs or head bolts with hardened washers are highly recommended to prevent issues such as galling of the aluminium bolt hole bosses. All fasteners should be lubricated appropriately with a quality engine assembly lubricant prior to installation.

It is highly recommended that valve to piston clearances are checked and corrected to minimum specifications if necessary. Minimum intake valve clearance should be 0.100" and the minimum exhaust valve clearance should be 0.110". Piston-to-head clearances also need to be checked and corrected to minimum specifications (minimum of 0.050").

Rocker geometry must be checked, making sure that the primary contact point of the roller (or pad) remains properly on the valve tip throughout its full range of motion. Inspection of the rockers, valve springs, retainers and pushrods should be made to ensure none of these components come into improper contact with each other. Some changes to pushrod length may need to be made to achieve correct valve train geometry.

If using these cylinder heads with the Proflow roller rockers, the guideplates and studs are not required to be used (supplied in assembled versions only).

Note: Rocker stud bosses and exhaust bolt holes have thread inserts installed (helicoil).

Torquing Sequence

The head bolt tightening sequence can be seen below in figure 1. Please tighten in three steps and refer to the head bolt manufacturer for correct torque specifications.

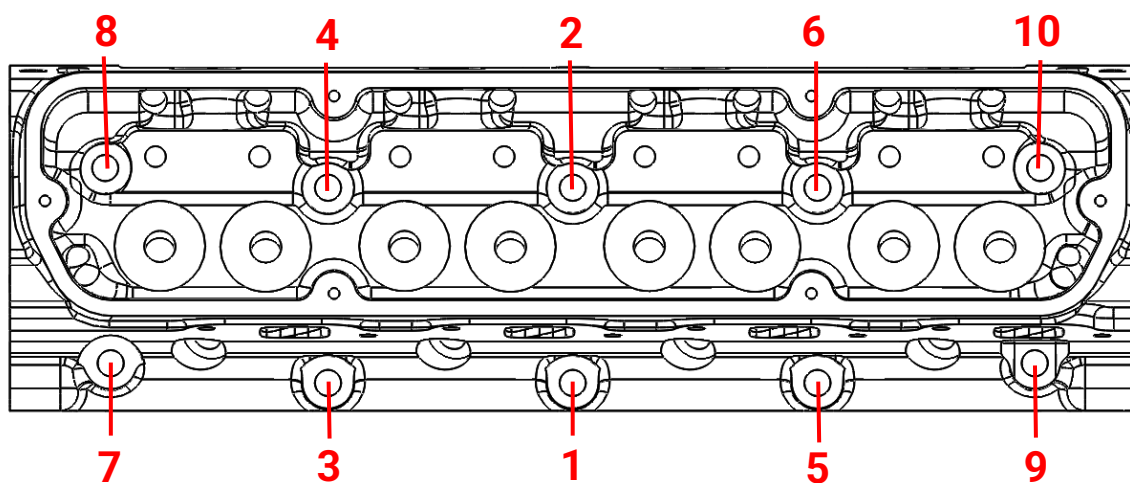

Figure 1

Cylinder Head Specifications

Combustion Chamber	64 cc	Valve Stem Diameter	8 mm
Intake Port Volume	200 cc	Valve Spring Pocket ID	1.650"
Intake Port Dimensions	2.150" x 1.290"	Valve Guide OD	0.530" (0.560" at base)
Exhaust Port Volume	72 cc	Maximum Valve Lift	0.650" (0.050" margin)
Exhaust Port Dimensions	1.440" x 1.270"	Rocker Stud Thread Size	7/16"-14
Spark Plug Location	OEM	Valve Angle	3°
Intake Valve Diameter	2.020"	Deck Thickness	0.780"
Exhaust Valve Diameter	1.60"	Installed Height (int.)	1.792" @ 141 lbs
Coil Bind	1.095"	Installed Height (exh.)	1.780" @ 144 lbs

Cylinder Head Flow Figures

Please note, all flowbenches are not created equal. This test was performed with a 4.030" bore as cast.

Intake (28")	Average Flow (CFM)	Exhaust (28")	Average Flow (CFM)
0.100"	70.0	0.100"	57.5
0.200"	132.0	0.200"	99.3
0.300"	195.0	0.300"	142.0
0.400"	242.0	0.400"	172.0
0.450"	256.0	0.450"	176.0
0.500"	261.0	0.500"	179.2
0.550"	266.0	0.550"	182.0
0.600"	273.6	0.600"	183.2
0.650"	285.2	0.650"	184.6
0.700"	289.0	0.700"	184.9

